



HBC-B Series Hall Effect Current Sensor

The HBC-B series current sensor is a closed loop device based on the principle of the Hall Effect and null balance method. The output from the current sensor is the balancing current which is a perfect image of the primary current reduced by the number of secondary turns at any time. This current can be expressed as a voltage by passing it through a resistor. It provides accurate electronic measurement of DC, AC or pulsed currents.

ELECTRICAL DATA

	HBC-50BS/BR	HBC-100BS/BR	HBC-200BS/BR	HBC-300BS/BR	
Rated Current	50	100	200	300	A
Measure Range	75(±18V,91Ω)	150(±18V,30Ω)	300(±18V,30Ω)	450(±18V,20Ω)	A
Turn	1: 1000	1: 1000	1: 2000	1: 3000	
Output current	50	100	100	100	mA
coil resister	20	20	25	35	Ω
Measuring resistance			10~50		Ω
Offset current			<0.15		mA
Supply voltage			±12 ~±18		V
zero point drift	-25~+85°C		±0.05~±0.3		mA
	-40~-25°C		±0.1~±0.5		mA
Linearity			±0.1		%FS
Band width	-1db		0~150		KHZ
Response time			≤1		μS
Galvanic isolation	50HZ,1min		3.0		KV
Operating temperature			-40~+85		°C
Storage temperature			-40~+90		°C

MUTING DIMENSIONS(FOR REFERENCE ONLY)

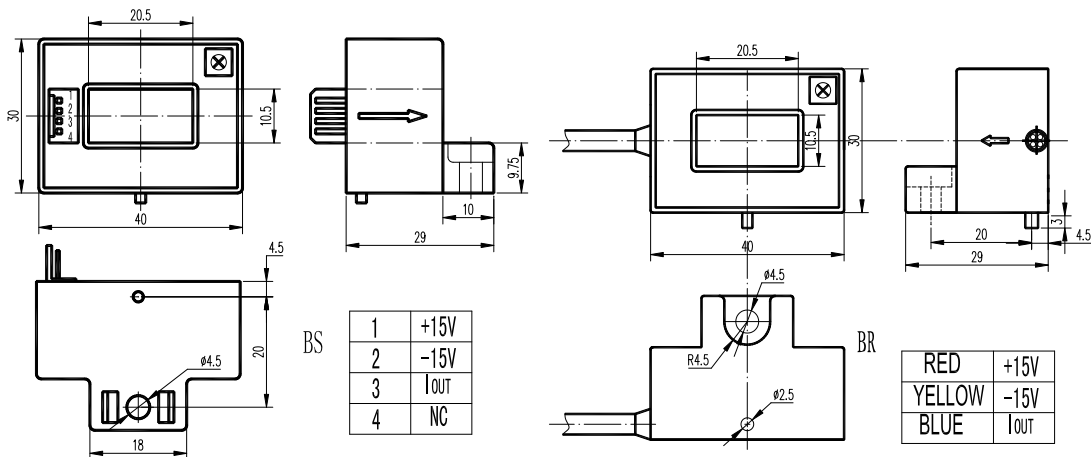

INSTRUCTIONS FOR USE

1. When the current will be measured goes through a sensor, the voltage will be measured at the output end. (Note: The false wiring may result in the damage of the sensor).
2. The output amplitude of the sensor can be adjusted according to users' requirements.